

CBCS SCHEME

USN

--	--	--	--	--	--	--	--	--	--

18ENG25

Second Semester B.Arch. Degree Examination, Dec.2019/Jan.2020 Building Structures – II

Time: 3 hrs.

Max. Marks: 100

Note: Answer any FIVE full questions, choosing one full question from each module.

Module-1

- 1 a. Explain different types of stresses and strain with neat sketches. (10 Marks)
b. Explain stress-strain curve for Mild Steel. (10 Marks)

OR

- 2 a. Write brief notes on Poisson's ratio, Elastic constants, Temperature stresses. (10 Marks)
b. A brass bar having cross section area of 1000 mm^2 is subjected to axial forces as shown in Fig.Q2(a). Calculate the force 'P' necessary for equilibrium of bar. Determine the total Elongation of the bar. Take $E = 1.05 \times 10^5 \text{ N/mm}^2$.

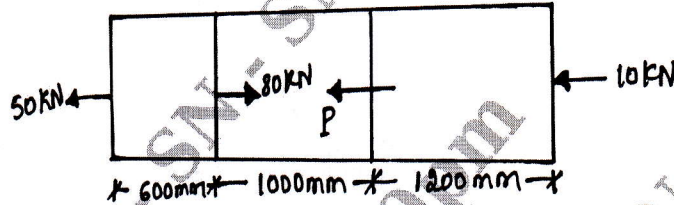

Fig.Q2(a)

(10 Marks)

Module-2

- 3 a. Explain the following:
(i) Bending Moment Diagram (BMD)
(ii) Shear Force Diagram (SFD)
(iii) Sign convention followed to represent BMD and SFD
(iv) Point of contraflexure (10 Marks)
b. Draw SFD and BMD for cantilever beam shown in the Fig.Q3(b).

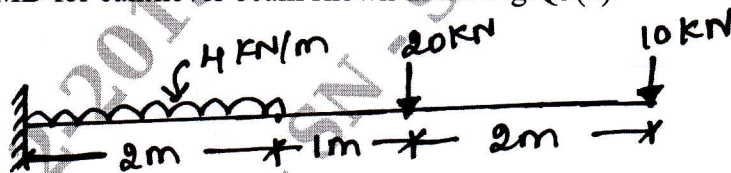

Fig.Q3(b)

(10 Marks)

OR

- 4 Draw BMD and SFD for overhanging beam shown in Fig.Q4. Clearly indicate point of contraflexure.

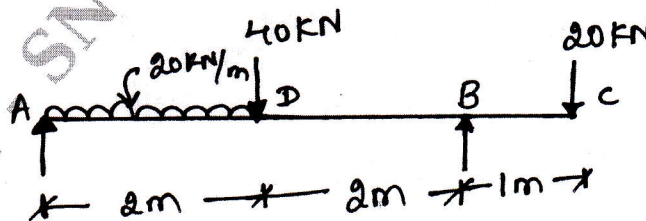

Fig.Q4

(20 Marks)

Important Note : 1. On completing your answers, compulsorily draw diagonal cross lines on the remaining blank pages.
2. Any revealing of identification, appeal to evaluator and /or equations written eg. 42+8 = 50, will be treated as malpractice.

Module-3

- 5 a. What are the assumptions made in bending theory and explain bending equation? (10 Marks)
 b. A beam with cross section shown in Fig.Q5(b) is simply supported and carries a maximum bending moment of 16 kN-m. Calculate maximum compressive and tensile stress.

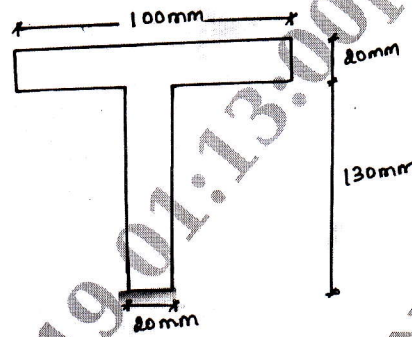

Fig.Q5(b)

(10 Marks)

OR

- 6 The unsymmetrical I-section shown in Fig.Q6 is subjected to a shear force of 40 kN. Draw the shear stress variation diagram across the depth.

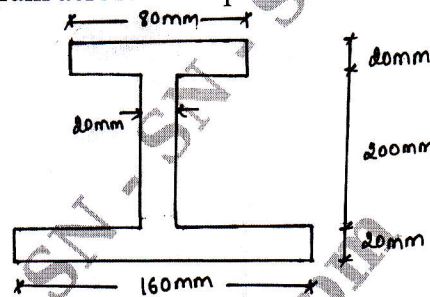

Fig.Q6

(20 Marks)

Module-4

- 7 a. Write expression for effective length of columns for various end conditions. (10 Marks)
 b. Explain Euler's formula for long columns. What are the assumptions and limitations of Euler's theory for critical load on long column? (10 Marks)

OR

- 8 a. Write the expressions for section modulus of:
 (i) Hollow rectangular section with symmetrically placed opening
 (ii) Triangular section
 (iii) Rectangular section (10 Marks)
 b. Determine the Euler's crippling load for an I-section column $400 \times 200 \times 10$ mm having length of 5m which is used as a strut with both ends fixed. Take $E = 2.1 \times 10^5$ N/mm². (10 Marks)

Module-5

- 9 Explain moment curvature equation. Determine a simply supported beam subjected to a central concentrated load. (20 Marks)

OR

- 10 A simply supported beam of 6m span subjected to a concentrated load of 18 kN at 4m from left support. Calculate:
 (i) The position and value of maximum deflection
 (ii) Slope at mid-span
 (iii) Deflection at the load point
 by Macaulay's method. Take $E = 200$ GPa and $I = 15 \times 10^6$ mm⁴. (20 Marks)
